



Off-Line Filter FGM 30 (60) / Pi 2728-57

Before putting hydraulic or lubrication systems into service, the entire system should be flushed. Depending on the application, low viscosity flushing oil or the actual operating oil may be used. The purpose of flushing the system is to protect system components externally via mobile filtration units to ensure residue from assembly is removed.

However, these mobile filtration units are also used to for the initial system fill or when changing the oil.

The filtration units are quiet and compact, with an easy to transport design.

Designed for in-house and mobile use

Small size

Low weight

Low noise emission

High vol. efficiency

Good suction performance

Gerotor principle

Not susceptible to contamination

Low pressure filter with a wide separation range and high filtration capacity



Technical Data

Technical Data

Pump:	Contaminant-resistant gerotor pump
Colour:	Motor RAL 7024/frame RAL 5002
Operating fluids:	Mineral oils per DIN 51524
Operating oil temperature:	max. 50 °C, briefly 65 °C
Seal:	Perbunan (NBR) or Viton (FPM) on request
Ambient temperature:	-15 °C to +40 °C
Electrical connection:	Motor circuit breaker with overvoltage release, 5 m oil-proof connection cable with 5-pin CEE shrouded plug 16 A IEC60309/3L+N+PE
Filter housing:	PI 2728-57 with optical contamination indicator, parallel flow through filter cartridges
Filter bypass:	Opening pressure Δp 3.5 bar
Contamination indicator:	Response pressure Δp 2.2 bar
Wheel kit:	Steel frame with integrated drip pan with drain, large polyamide wheels, swivel wheels with brake, fold-away handle for pulling the aggregate, storage hooks for connecting cable and hoses
Oil hoses:	clear PVC hoses with integrated steel wire coil, with strainer as suction hose coarse filter, galvanised steel pipe pressure lance

Electric motors

Voltage/frequency	
FGM 30:	220/380 V - 230/400 V - 240/415 V 50 Hz; 460 V 60 Hz Electr. motor per NEMA; UL, CSA, EAC approval
FGM 60:	220/380 – 245/420V 50Hz 220/380 – 280/480V 60Hz
Thermal stability:	Class of insulation F, utilisation per Class B
Design:	three-phase asynchronous squirrel-cage induction motor totally enclosed, fan cooled
Degree of protection:	Motor IP55 Plug IP44
on request:	other voltages higher motor power for higher viscosities UL- or CSA-approved motors higher protection class

The motors comply with the IEC 60034 standards

Aggregate	FGM 30	FGM 60
Flow rate:	29 L/min	58 L/min
Power output/number of pins/ rated current at 400 V:	0.75 kW/4/1.6 A	2.2 kW/4/4.6 A
Sound pressure level per ISO 3744:	61 dB(A)	64 dB(A)
Speed (rpm):	1410	1410
max. working pressure:	7 bar	7 bar
Suction pressure: briefly:	-0.4 bar -0.6 bar	-0.4 bar -0.6 bar
max. oil viscosity:	500 mm ² /s	500 mm ² /s
Weight:	approx. 60 kg	approx. 70 kg

Accessories (included)

	30 L/min.	60 L/min.	Length
Suction hose	DN 25	DN 32	L = 2 m
Pressure hose	DN 20	DN 20	L = 2 m

Screw-in cartridge 3 µm, 6 µm, 10 µm, 25 µm (not included)

Dimensions (mm/inch)

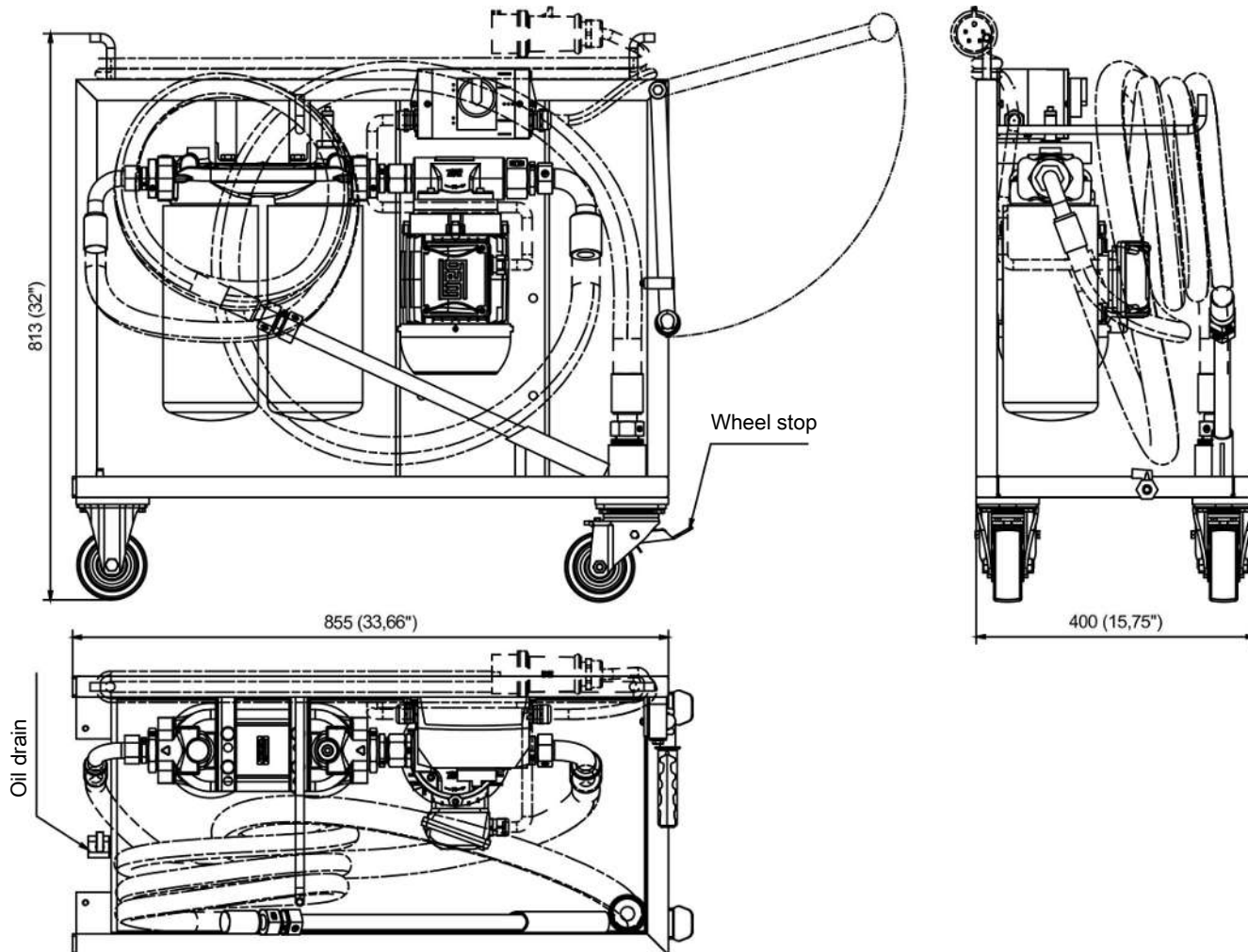

Ordering instructions

Filtration units

Item no.	Type	Mains frequency
27002030IE3	FGM 30/Pi 2728-50Hz-57	50 Hz
27002031IE3	FGM 30/Pi 2728-60Hz-57	60 Hz
27002020IE3	FGM 60/Pi 2728-50Hz-57	50 Hz
27002021IE3	FGM 60/Pi 2728-60Hz-57	60 Hz

Screw-in cartridge (not included)

Item no.	Type	Fineness
70541536	PX37-13-2	3 µm
70541537	PX37-13-2	6 µm
70541538	PX37-13-2	10 µm
70541539	PX37-13-2	25 µm